



Submittal Package for: 1100mm (42" Nominal I.D.) HDPE-Lined Concrete Sanitary Pipe

PERFECT  PIPE

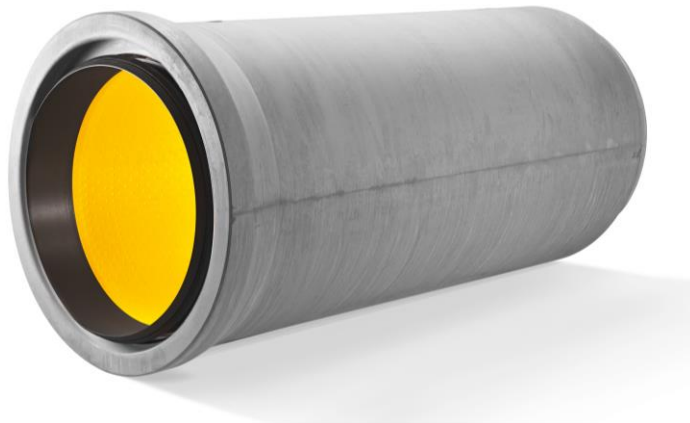

Table of Contents

- Introduction
- Component Summary and Definitions
- Shop Drawing
- HDPE Lining Data
- Thermoplastic Coupler & Gasket Data
- HDPE Lining Data



AMERICAN

CONCRETE PRODUCTS

Perfect Pipe Submittal Package

To whom it may concern,

We are pleased to introduce the “Perfect Pipe” system, an HDPE-lined concrete sanitary pipe for gravity sewer that protects against Microbial Induced Corrosion (MIC) and Inflow and Infiltration (I&I). Perfect Pipe builds upon the existing concept of using high strength reinforced concrete pipe (6,000 PSI compressive strength) combined with the corrosion, abrasion and chemical resistance of an HDPE liner.

The Perfect Pipe system solves the challenge posed by flexible-wall pipe in deep-bury installations. While non-corrosive, flexible-wall pipe requires a concrete-encasement or slip-lining to prevent buoyancy and deflection when placed in overarching soils. The Perfect Pipe coupling system eliminates confined space risk associated with welding conventional lined concrete pipe and offers construction companies a considerable cost advantage via simplified installation.

Enclosed for your review is a submittal package containing material, manufacturing and testing data for the Perfect Pipe system. A list of installations has been supplied in the Annex, including a 3-Part CSI Format product specification.

Sincerely,

Charles Moses, CDT
AMERICAN CONCRETE PRODUCTS
(402) 250-6545
cmoses@amconco.com

Components and Definitions

2 DEFINITIONS

Barrel	The body of the pipe
Bell	The female end of the pipe
Coupler	A plastic ring made of polypropylene which house two double tilting gaskets used to connect the pipes. The coupler is factory installed in the bell end of the pipe.
Gasket	Double tilting gasket rest on the coupler provides hydrostatic pressure resistance
Liner	High density polyethene yellow liner with anchors at the back that is cast in to the concrete covering entire interior surface
Load Transmission Ring	A rubber ring rests at the spigot protecting concrete to concrete impact during installation
Spigot	The male end of the pipe

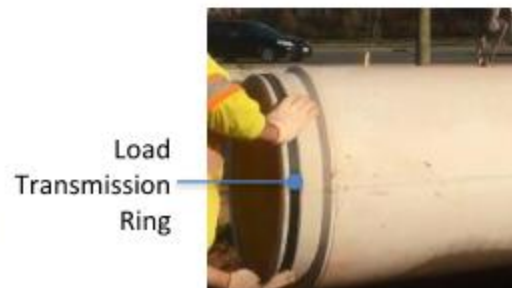
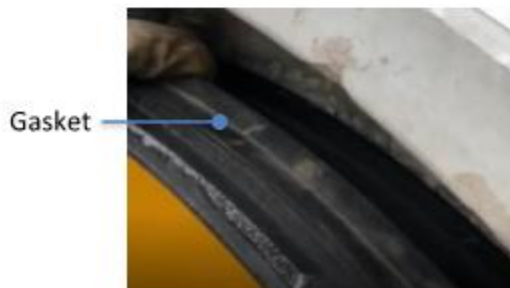
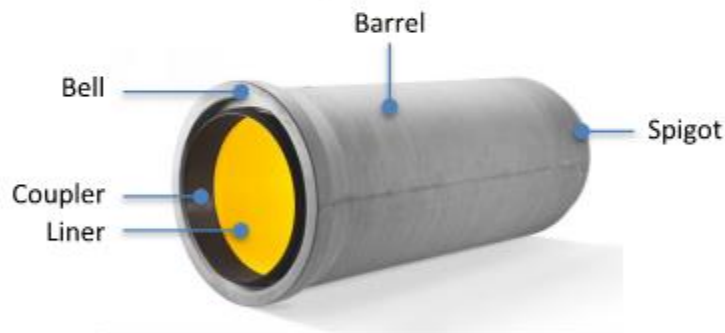
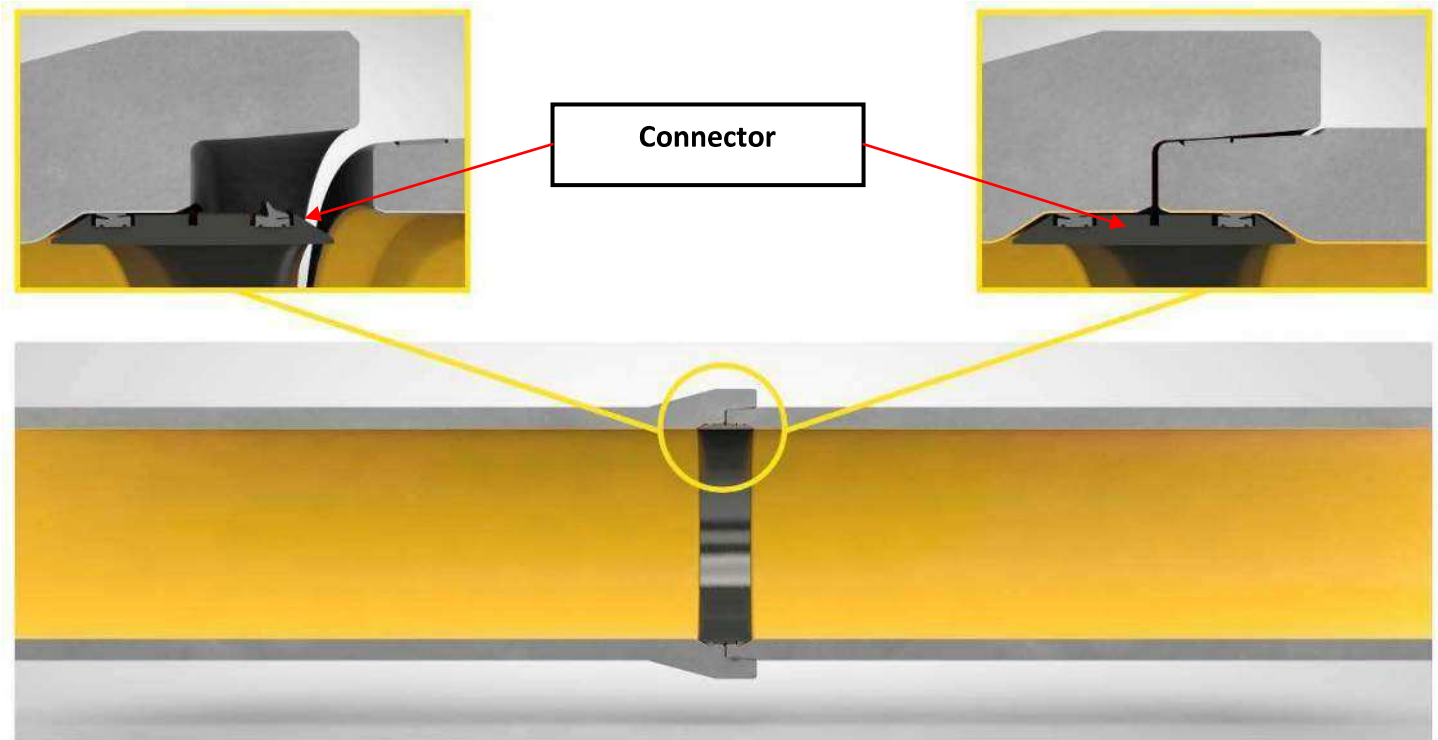

Illustration of Typical Perfect Pipe Joint



The internal Perfect Connector does not affect the concrete pipe joint that may be designed to comply with local specification and conditions. For field testable joints, a gasketed joint can be designed in the RCP Spigot.

Ein mögliches Lastübertragungsband ist keine Dichtung und übernimmt somit auch keinerlei Funktion einer Dichtung!
 Chamber exclusively for load transfer belt. A possible load transfer belt is no gasket and thus assumes no function of as gasket!

DETAIL J

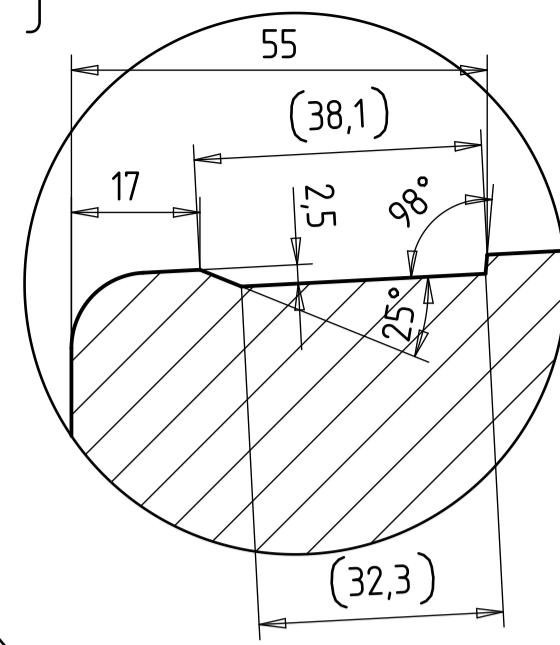

DETAIL C

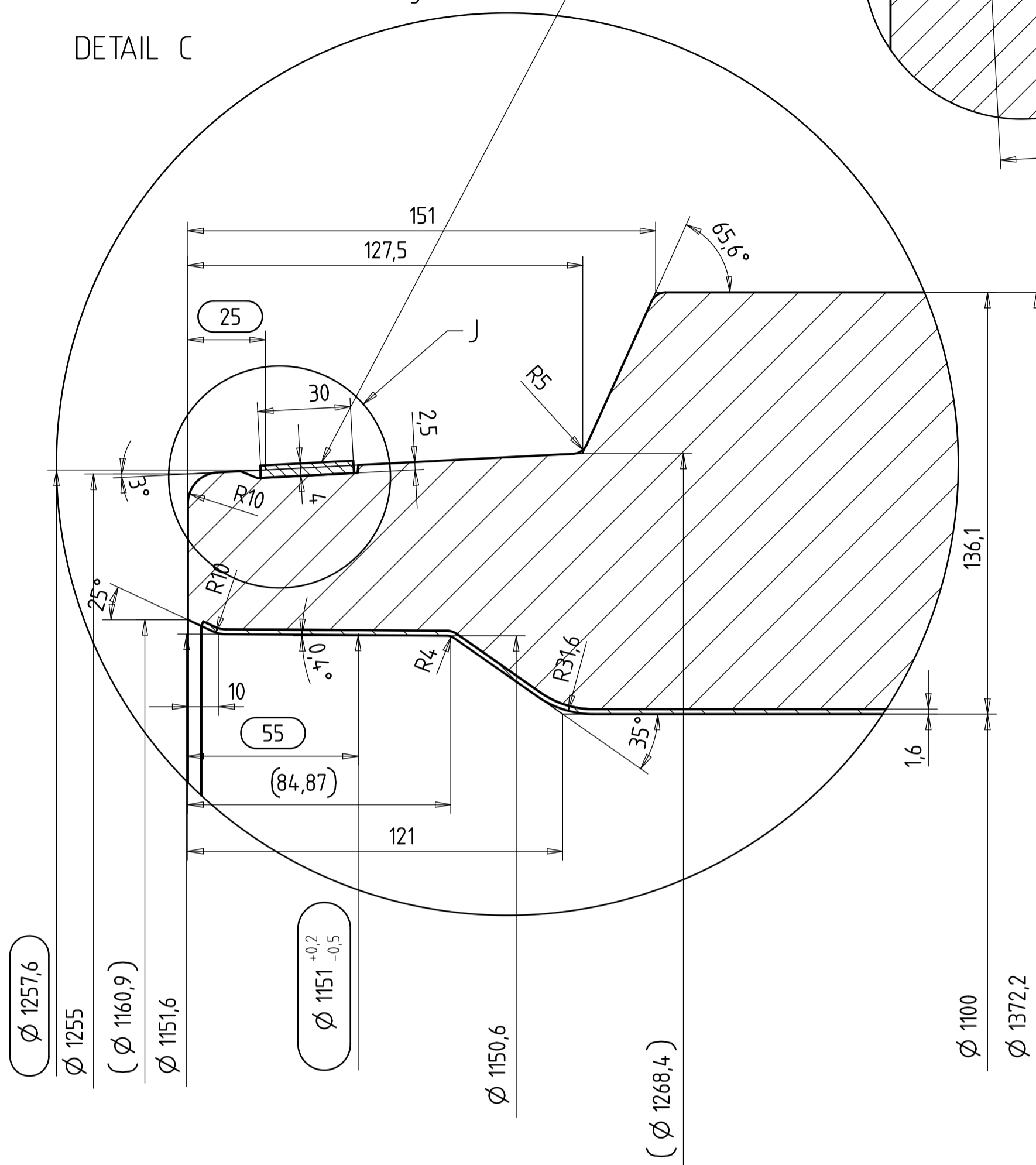

DETAIL B

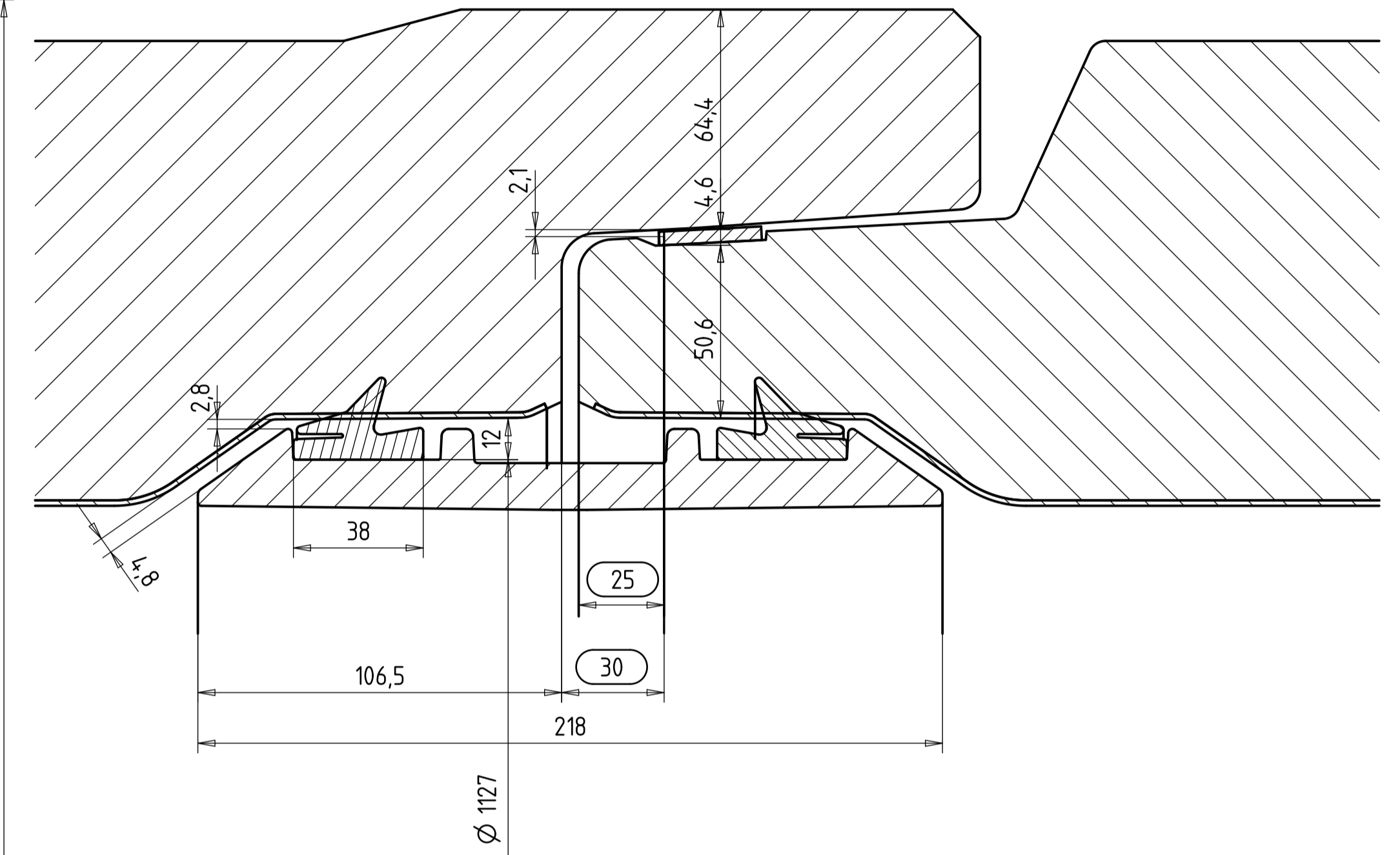
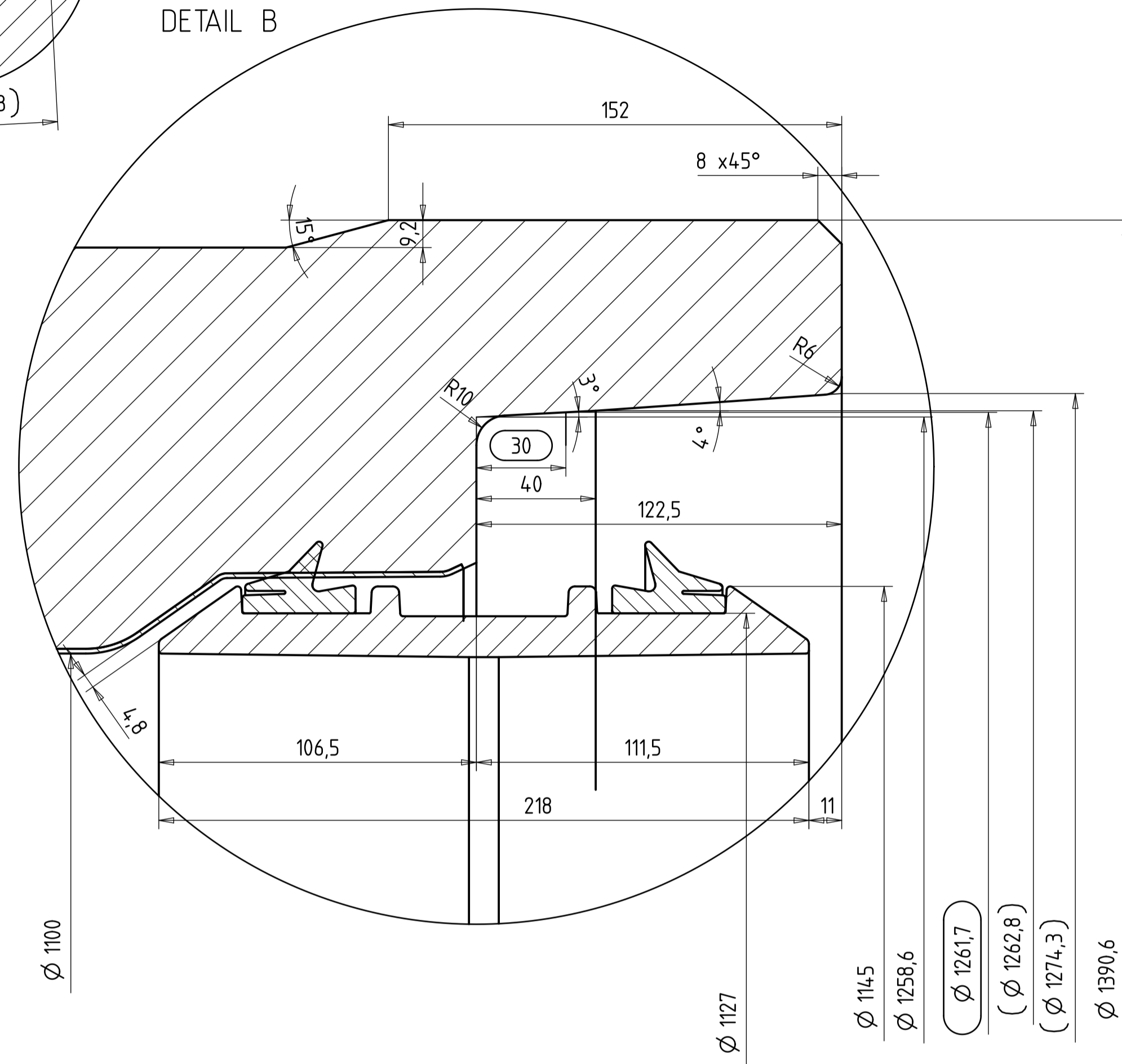

SCHNITT A-A

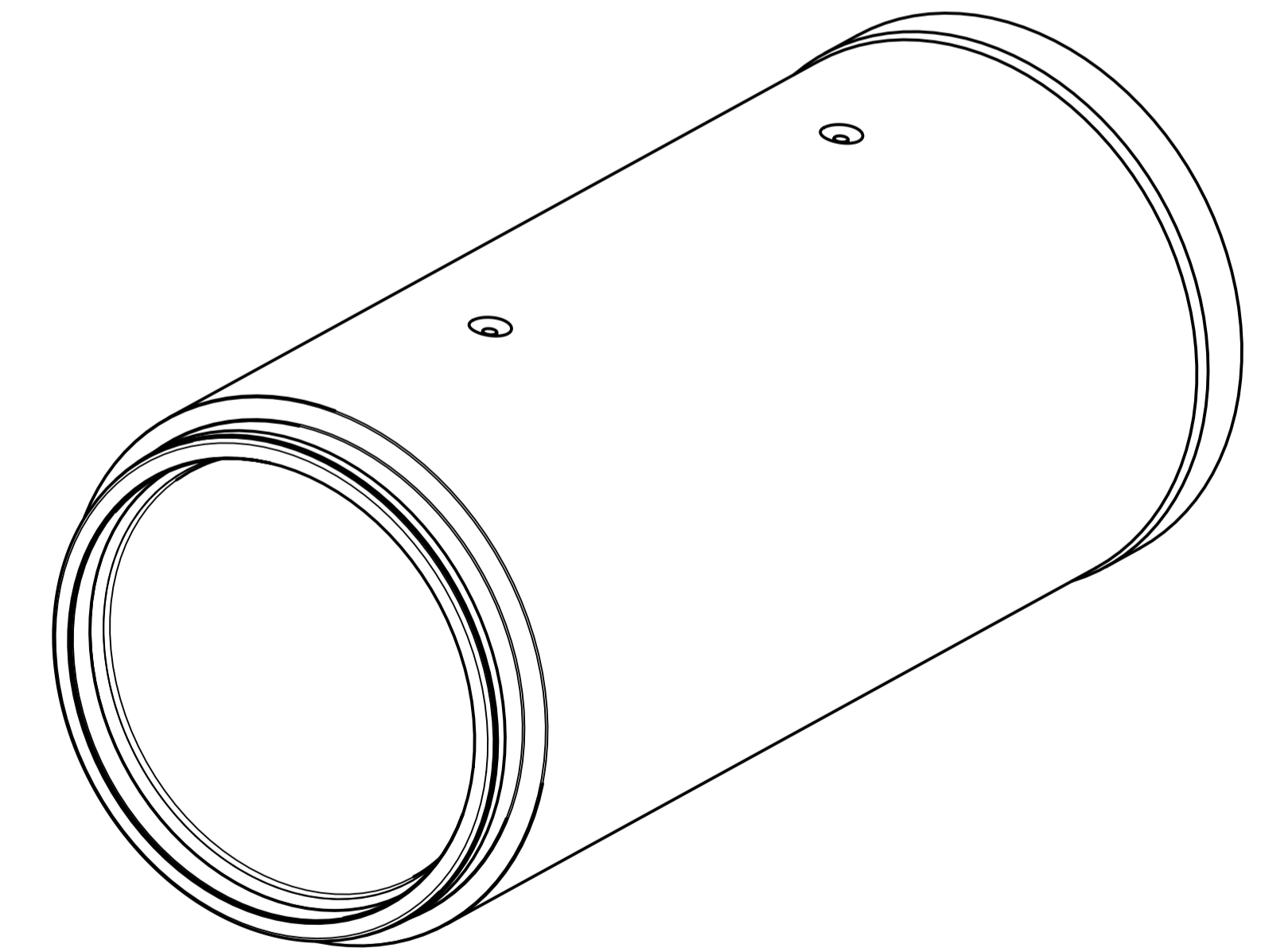
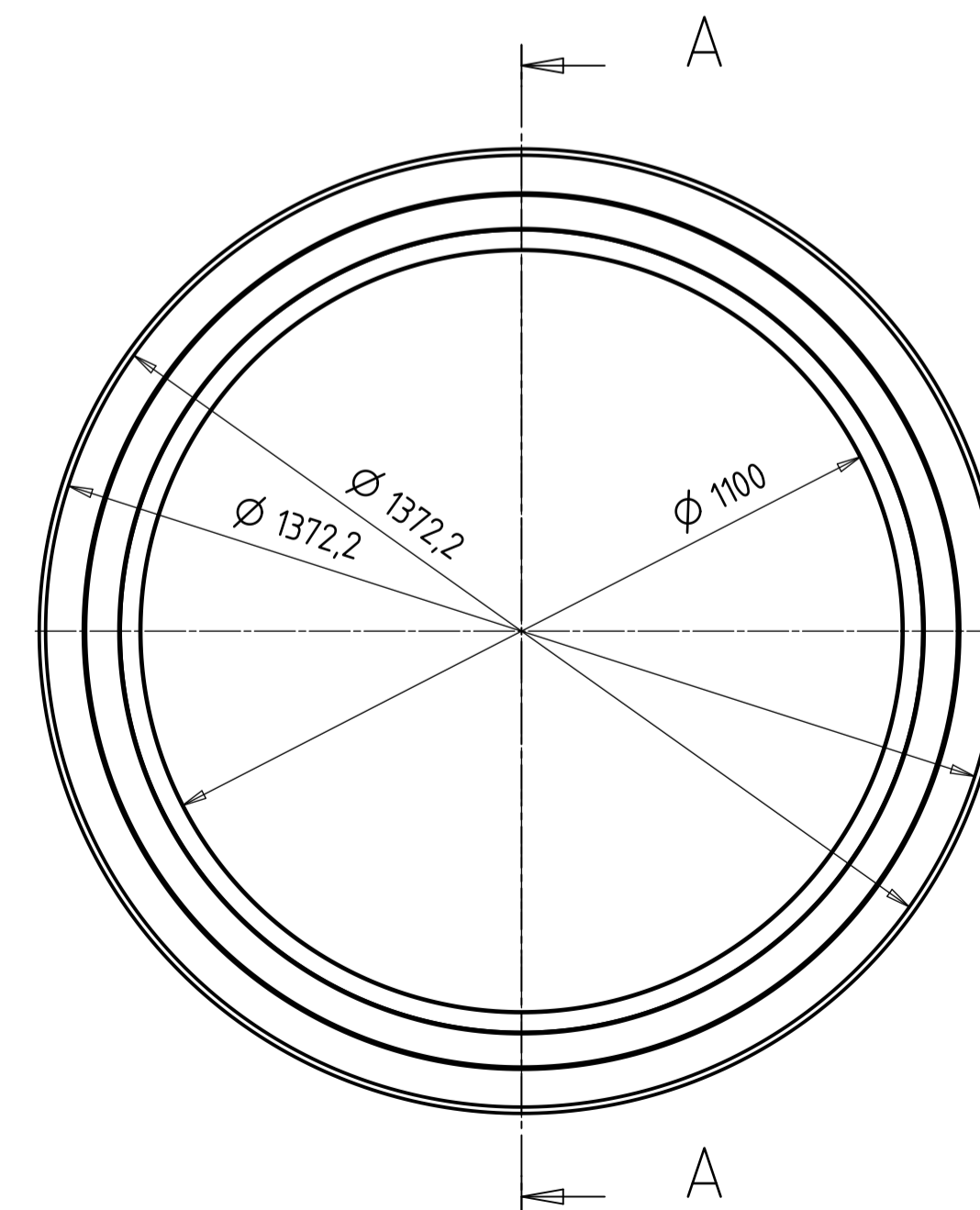
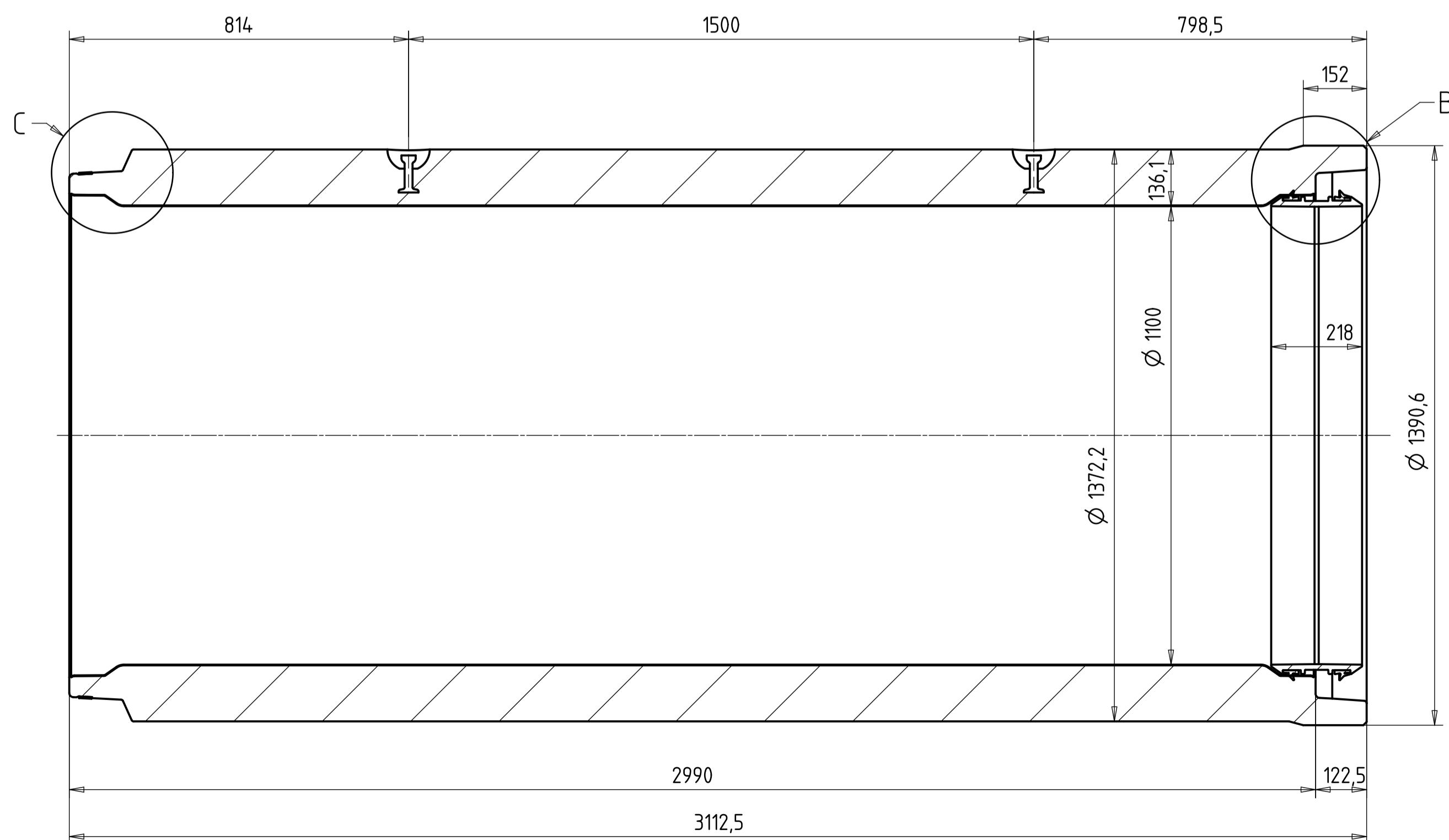

Bemerkung	Änderungsvermerk		Maßstab	Auftragsnummer	DXF - Kontur
	Allgemeintoleranz				
	ISO 2768 mittel		Benennung		
	Datum		Name		Rohr K-M 1100/136,1/3000 Liner Connector KLP14, DAR,TSS
Erstellt		Name		Gesamtgewicht	
18.04.2018		Mair Robert		3743.538	
Geprüft		Name		Zeichnungsnr.	
18.04.2018		Standhartinger G		750590-00-K1	
Status		Name		Schlüsselbauer	
Freigegeben		Name		TECHNOLOGY GmbH & Co KG	
Index		Name		4673 GASPOL ISCHNÖFEN/AUSTRIA	
Änderung		Name		Tel.: +43(0) 7335 7144 0 Fax 7144 55	
Datum		Name		e-mail: stonke@schlüsselbauer.at http://www.skb.at	

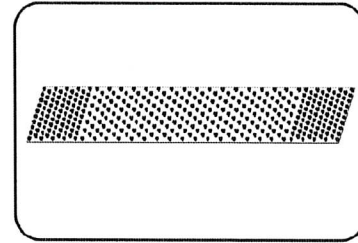

- **Perfect Liner**
studs 7,8 mm
extruded
- **Extrusion-welding**
- **PE yellow RAL 1018**

Typecode 21.559

	Property	Standard	Unit	Product
	Specific density at 23 °C	ISO 1183	g/cm ³	0.94-0.96
	Melt Flow rate MFR 190/5	ISO 1133	g/10min	1.6-2.0
mechanical properties	Tensile stress at yield	ISO 527	MPa	≥ 12
	Elongation at yield	ISO 527	%	≥ 8
	Elongation at break	ISO 527	%	> 400
	Modulus of elasticity	ISO 527	MPa	≥620
System properties	Pull Out Resistance at 23 °C Tensile Test 100 N/sec (short term)	DIN ISO 4624	N/Noppe kN/m ²	≥350 ≥420
	Backpressure Resistance at 23 °C	DIBt- Pruefmethode	1,5 bar/1000h	fulfilled
	Max. Working Temperature	-	°C	60
	Linear coefficient of thermal expansion	DIN 53752	K ⁻¹ x 10 ⁻⁴	1.8
	Flammability	UL 94 DIN 4102 EN 13501	-	94-HB B2 Class E
other properties	UV stabilized	-	-	3 year Central Europe 15 month South- western Asia
	Colour	-	-	yellow

Rev.001_30.08.2016

The data in this table are approximate values and based upon results of the internal inspection, data of raw material suppliers as well as tests in the course of approval procedures and external inspections. The results can differ slightly from the indicated mean values in longitudinal and transverse direction and due to different nominal thicknesses and raw materials. In any case requirements relating to a special project (tender documents) have to be agreed with AGRU.

Independent of the indicated test standards, internal tests and data on test certificates are generally carried out in accordance with the appropriate test procedures according to OENORM (Austrian Standard) resp. DIN (German Standard) or EN ISO. AGRU assumes no liability in connection with the use of this data. The specifications on this sheets are subject to change without notice.

PERFECT Connector DN700 – 1500

- **PERFECT Connector**
injected molded
plug-in-connection

- **PP-GF black**



Technical properties for PPB material for PERFECT Connector as per DIBT Approval Z-42.5-552.

	Property	Standard	Unit	PP-GF
MECHANICAL PROPERTIES	Density	DIN EN ISO 1183-1	g/cm ³	1,215 – 1,285
	Melt Flow Rate (MFR 230°C / 2,16 kg)	DIN EN ISO 1133	g/10 min	3,0 – 6,0
	Oxidation Induction Time (OIT bei 210°C)	DIN EN ISO 11357-6	min	> 40
	Tensile Strength	DIN EN ISO 527-1	MPa	≥ 95
	Tensile Strain at Break	DIN EN ISO 527-1	%	≥ 2
	Flexural Modulus	DIN EN ISO 178	MPa	≥ 6.500
	Flexural Strength	DIN EN ISO 178	MPa	≥ 138
	Charpy Impact Strength (23°C)	DIN EN ISO 179-1	kJ/m ²	≥ 35

Subject to errors and modifications.

Declaration of performance

Ref.-Nr. 2020/015

1. Elastomeric seals ASTM C 1619 class A
2. **hardness category 50 - nominal hardness 55 EPDM**
3. Components and sealing products for sewer
4. DS Seals GmbH, Lise-Meitner-Straße 1, 48301 Nottuln
5. not relevant
6. System 4 (ASTM C 1619 class A)
7. not relevant
8. not relevant
9. declared performance

Main features	performance	harmonized technical specification
Tolerances	see factory documents	ISO 3302
Hardness	+/- 5 IRHD	ASTM D2240
Tensile strength	≥ 2300 PSI	ASTM D412
Elongation at break	≥ 425 %	ASTM D412
Compression set in air	≤ 20 % (22h at 70°C)	ASTM D395-B
Ageing in air	≥ -15 % (96h at 70°C)	ASTM D573
	≥ -20 (96h at 70°C)	
Volumen change in water	≤ 5 (48h bei 70°C)	ASTM D471
Ozone resistance	No cracks	ASTM D1149
Strength of the joint	Elongation 100%	ASTM D2527

Seals made of EPDM – 55

DS KLP

1. The performance of the product in accordance with paragraphs 1. and 2. corresponds to the declared performance for number 9. The company DS Dichtungstechnik, however, guarantees that the integrated seal in the sleeve for pipes made of concrete, steel fiber concrete, reinforced concrete and driving pipes with circular cut correspond to the performance of the ASTM C 1619 class A.
2. Responsible for creating this performance is the manufacturer's declaration referred to in point 4. Signed on behalf of the manufacturer and the name of the manufacturer of:

Dipl.-Ing. Albert Steinhoff, Managing Director

Nottuln, 06.01.2020

